



2010 *International* Application Guide • Volume 9 • Issue 1 • 1-11-10



UVL855R UVL SERIES™

UVL855R *UVL Series*™

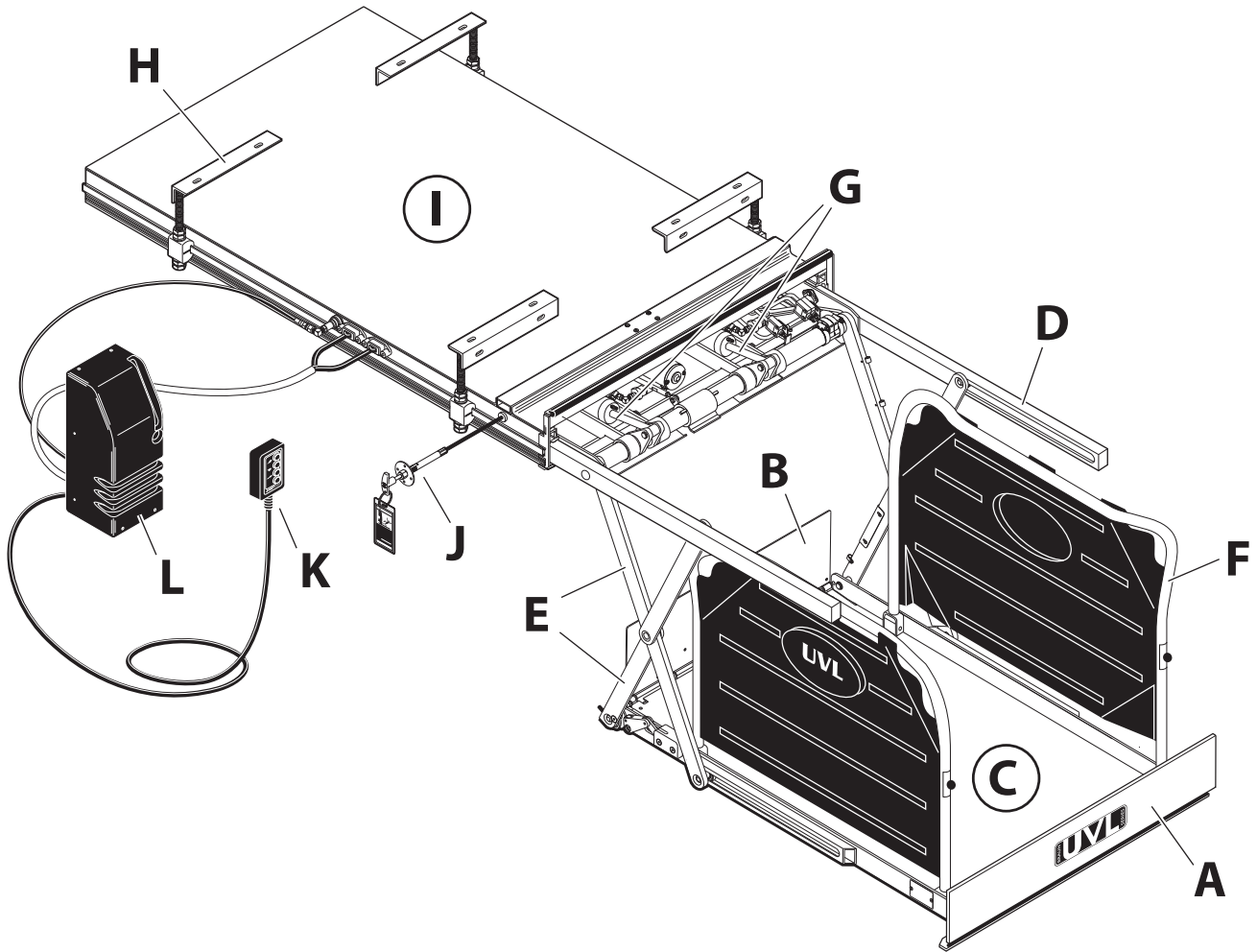

A - Automatic Outboard Barrier	G - Hydraulic Cylinder (2)
B - Inboard Barrier	H - Lift Mounting Brackets (6)
C - Platform	I - Lift Housing (Cassette)
D - Rolling Horizontal Arms (2)	J - Platform Cable-Activated Manual Release
E - Lifting Arms (4)	K - Hand-Held Control Box
F - Handrail (2)	L - Pump Module

UVL855R *UVL Series*™ Specifications

General Function: Electrohydraulic, power up/gravity down operation, power in/out

Operation: Hydraulic pump with two lifting cylinders

Control: hand-held control

Hydraulic: Pressure Max. 3,249 psi (224 bar), Fluid is Hydraulic/HFA Aviation, Oil reservoir is .25 gal (.95 L)

Construction: Aluminum Housing with Steel inner structure with powder coat finish

Lift Weight: 580 lbs (263 kg)

Lifting Capacity: 750 lbs (340 kg)

Operating Temperature: 19°F to 149°F (-7°C to 65°C)

Power Supply: 12V DC (optional 24V DC)

Current Consumption: Max. 120A (12V) - Max. 60A (24V)



UVL855R UVL Series™ Dimensions

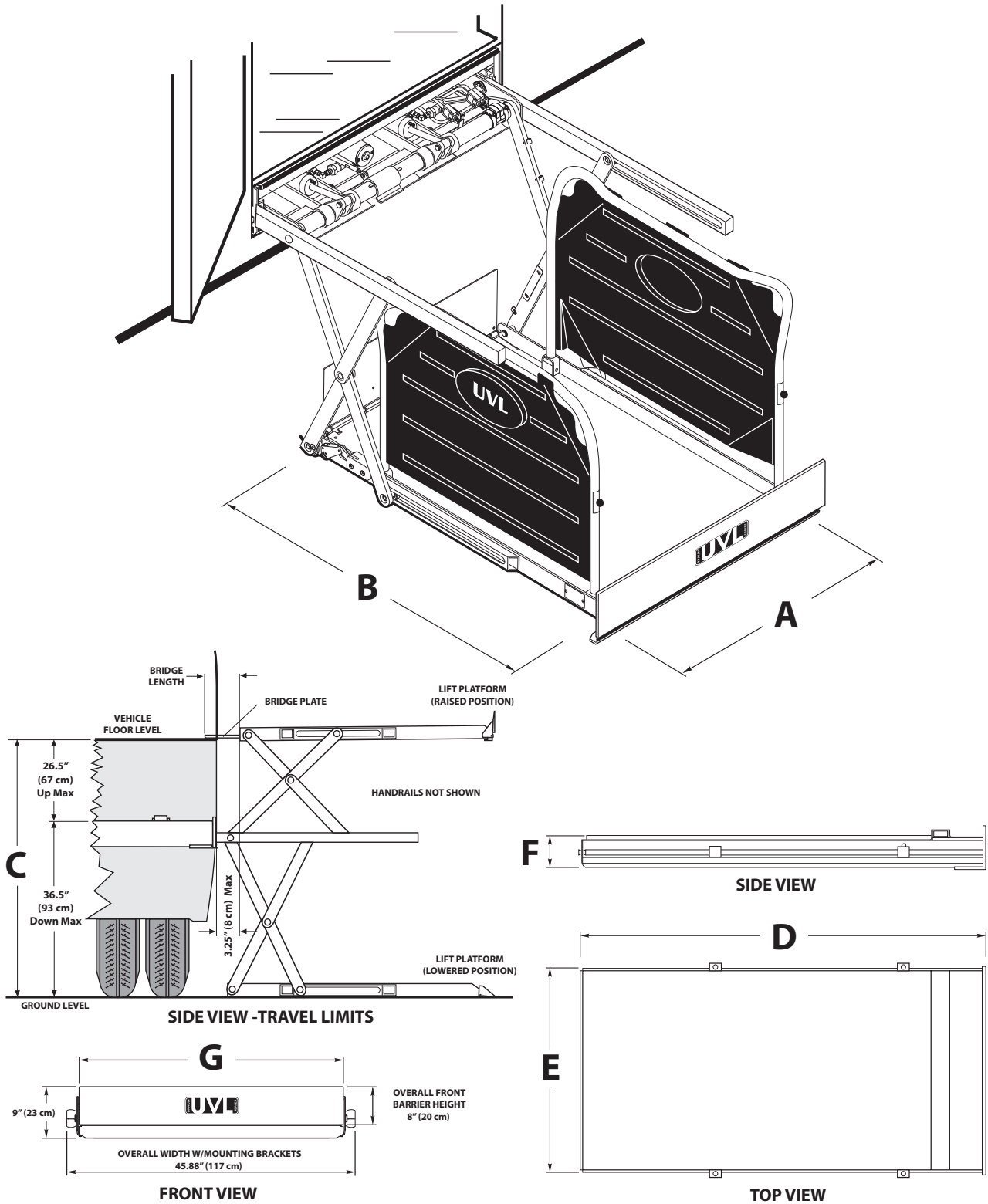

All dimensions are for reference only.

UVL855R UVL Series		A	B	C	D	E	F	G	
Lift Model Number	Operation		Clear Platform Width	Clear Platform Length	Max. Floor to Ground	Cassette Length	Cassette Width	Cassette Height	Min. Clear Door Opening Width
	User	Attd.							
UVL855R		X	30"(76cm)	53"(135cm)	63"(160cm)	72.25"(184cm)	43.5"(110cm)	5"(13cm)	43.5"(110cm)

UVL855R *UVL Series*™ Features



- fully automatic lift, operated by an attendant
- mounts in a dedicated door application - out of sight and out of the way, providing more flexibility in floor plan design
- aluminum housing is fully enclosed to be weather tight
- features a power pack remotely-mounted hydraulic pump with power up/ gravity down operation
- handheld 4-button pendant control operates all lift functions
- slip-resistant platform
- automatic outboard barrier engages before platform leaves ground
- mechanical inboard barrier / bridge plate
- lift will not stow with weight on the platform
- manual back-up system as standard feature
- rattle-free environment inside, providing a pleasant quiet ride
- diagnostic system for easy troubleshooting
- bearings are sealed or self-lubricating
- all functions operate from a digital logic board located inside the power pack
- durable high-gloss powder coated finish



www.braunmobility.com/international

ISO 9001:2000

631 West 11th Street, Winamac, IN 46996, USA Phone: +1 574 946 6153 Fax: +1 574 946 4670

All illustrations, descriptions and specifications in this guide are based on the latest product information available at the time of publication. The Braun Corporation reserves the right to make changes at any time without notice.

© 2010 The Braun Corporation